



# VERRO SERIES: VBT-SB2

## Two Burner Boiling Top

Project: \_\_\_\_\_ Item: \_\_\_\_\_



VBT-SB2

### Standard Features:

- AISI Grade Stainless Steel
- Heavy duty complete stainless steel cabinet frame
- 31MJ black enameled Italian made burner
- Heavy duty Italian made vitreous enameled trivets
- Removable pressed top spillage tray for easy cleaning
- Removable heavy duty two-piece burner for easy cleaning
- Flame Failure - Included as standard
- Multi-setting gas valve – Allows greater regulation of flame setting
- Easy access to all components for servicing and adjustments
- Easy to clean fat spillage tray

### Options:

- Natural or LPG Gas
- PLT – With Pilot
- Non-swivel rear castors – Set of two

### Specifications:

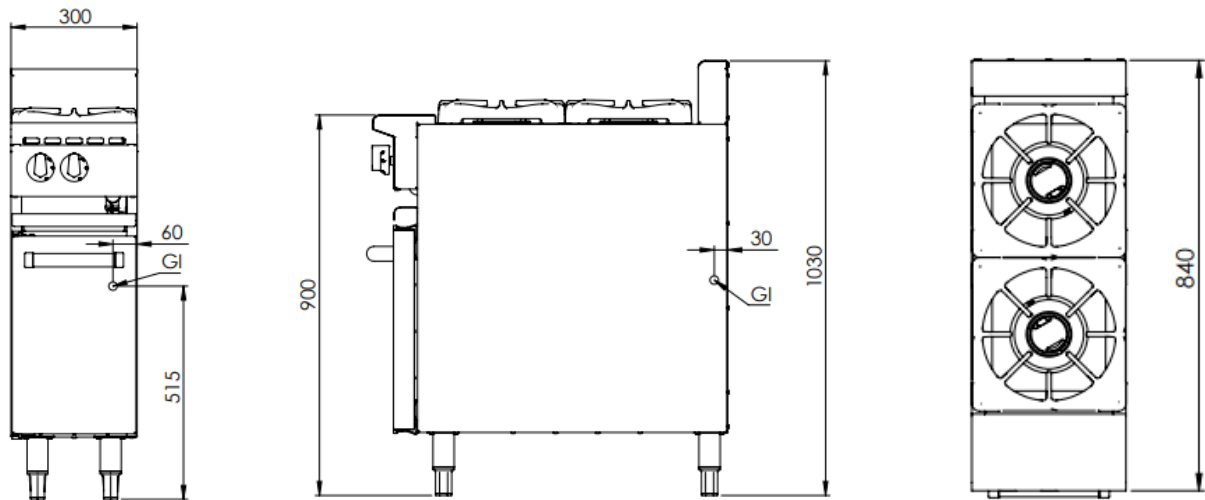

MODEL	LENGTH (mm)	DEPTH (mm)	HEIGHT (mm)	NET WEIGHT (kg)	GAS CONSUMPTION (Mj/h)	
					NG	LPG
VBT-SB2	300	840	1030	-	62	50

### Connections:

GAS (GI) (BSP)	SUPPLY PRESSURE (kPa)	
	NG	LPG
3/4" (M)	1.0	2.6

- Gas regulator is included with the unit
- **Must** be installed by an authorised installer in accordance to **AS/NZS5601 refer to current version**

**Due to ongoing Product Development, Product Improvement and Research, B+S Commercial Kitchens reserves the right to alter specification without notice.**

**Approval Number: GMK 10686**



B+S Commercial Kitchens  
 57 Plateau Road Reservoir VIC 3073 Australia | +61 3 9469 4754  
 info@bscommercialkitchens.com | www.bscommercialkitchens.com

