

**Model: SFT45-4**

SPEC SHEET	SFT45-4
Classification	Freezer
Cabinet Dimension (WxDxH mm)	1260x850x1926
Capacity (Liters)	1210
Inner Temperature	-21°C~-12°C
Doors	4
Number of Shelves	6
Refrigent	R-404a
Compressor (Hp)	1
Cooling Type	Fan cooling type
Insulation Type	Polyurethane / Cyclopentane + CFC Free
Temperature Control Type	Digital
Amps (A)	5.3
Voltage (V/Hz/Ph)	240V 50Hz 1Ph
Power (W)	774
Weight (Kg)	142

**PLAN VIEW**

(unit: mm)

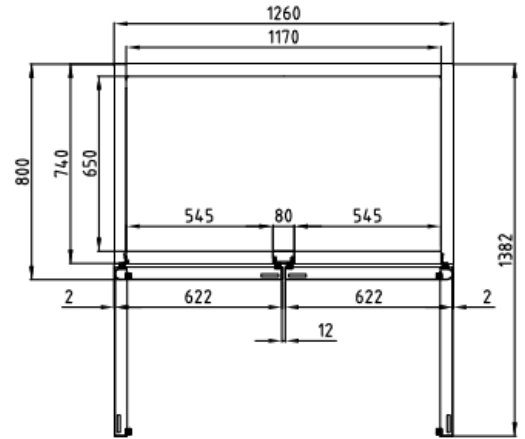

**TOP VIEW**

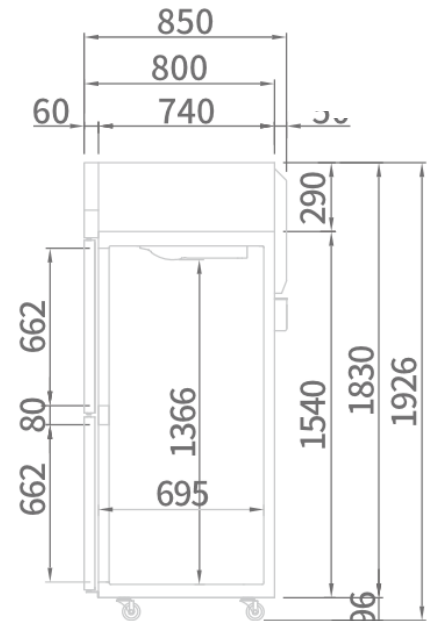

**SIDE VIEW**

Size Optional 96

