

# Vaccine Refrigerators

## Features:

- Digital controller with digital temperature display
- Temperature data logger included
- Dynamic fan forced cooling system with automatic defrosting
- Double glazed glass door
- White External and Interior Finish
- Internal LED light
- Frequency/voltage: 50Hz/220-240 V
- Leveling adjustable feet
- QCPP approved
- Plastic coated steel shelves
- Battery backup controller
- Refrigerant: R134a
- Ambient temperatures from +16°C to +32°C



## MV300



Temperature data logger included



Battery backup for controller in case of power outage

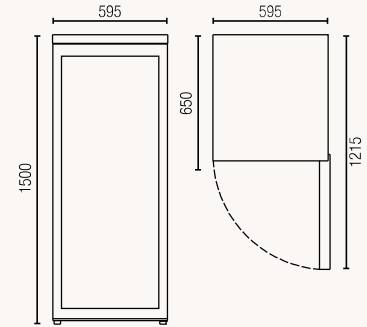

Quality Care Pharmacy Program  
An initiative of The Pharmacy Guild of Australia

**Gross/Net volume:** 308/300 L

**Exterior dimensions in mm:** 595w x 650d x 1500h

**Number of shelves:** 8

**Max. noise level:** 55 dB

**Temperature range:** +2°C to +8°C

**Gross/net weight:** 78/72 kg

**Energy consumption in 24h:** 2.9 kWh

## MV400



Temperature data logger included



Battery backup for controller in case of power outage

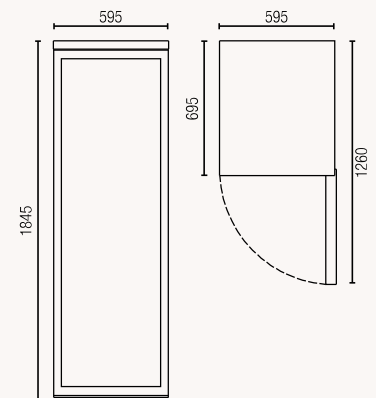

Quality Care Pharmacy Program  
An initiative of The Pharmacy Guild of Australia

**Gross/Net volume:** 408/400 L

**Exterior dimensions in mm:** 595w x 695d x 1845h

**Number of shelves:** 8

**Max. noise level:** 65 dB

**Temperature range:** +2°C to +8°C

**Gross/net weight:** 92/84 kg

**Energy consumption in 24h:** 3.1 kWh